

groov▶▶*e*

Headrest Mount



GV-WM7
In-Car Holder
for Tablets

groov-e.co.uk



30 Day Right To Return

We do not envisage any problems occurring with your groov-e GV-WM7 Headrest Mount. However, for your peace of mind, should any fault occur, please return it within 30 days to your retailer with proof of purchase for an exchange or refund.



12 Month Guarantee

This product is guaranteed for twelve months. Please retain your receipt as this will be required as proof of purchase in the event that the device does not perform as expected then please contact your original point of purchase, should you require further assistance then please contact us.



Extended Warranty

Please register your product within 30 days from date of purchase www.groov-e.co.uk/warranty. Proof of purchase required.



Contact Us

Reach out to us at info@groov-e.co.uk or visit www.groov-e.co.uk

“Congratulations on your purchase and **Thank You** for choosing the groov-e GV-WM07 Headrest Mount In-Car Holder for Tablets.”

⚠ IMPORTANT SAFETY INFORMATION

Please read this important information carefully before you use the GV-WM07 Headrest Mount In-Car Holder for Tablets and save it for future reference.

OVERVIEW

IN THE BOX

- **1 x** GV-WM07 Headrest Mount
- **1 x** User manual

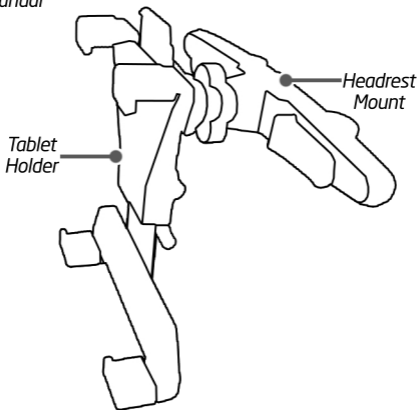

OPERATION

Installing the Headrest Mount

1. Fit the holder bracket (figure 1, pos A) around the headrest brackets (figure 1, pos. C) and fold down the quick lock (figure 1, pos B).

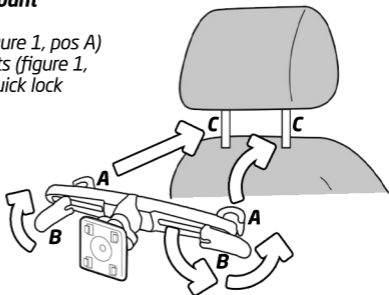

2. Position the holder in the four-point adapter bracket and slide both parts together (figure 2).

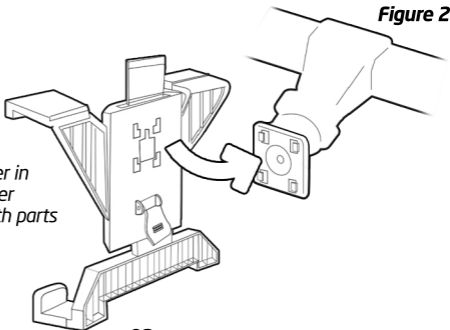

OPERATION

Using the Tablet Holder

Figure 3

1. Fold up the quick lock (figure 3, pos. A) and place the tablet inside the four support lugs. Adjust the distance between the support lugs so that the unit sits firmly and fold down the quick lock.

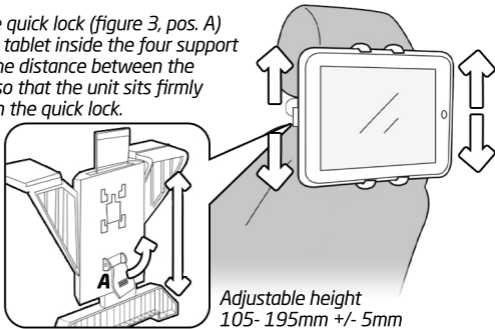

2. You can angle the tablet 360° there is a lockable joint (figure 4, pos.A). By loosening the locking knob (figure 4, pos. B), so the joint moves easily. Adjust the holder to the required position and then tighten the locking knob securely.

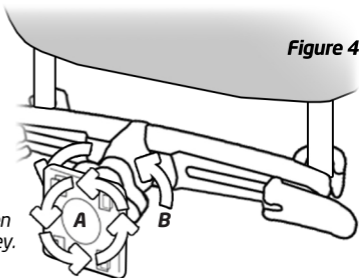

Figure 4

FEATURES

- *Suitable with most 7-13 inch tablets*
 - *Adjustable height 105- 195mm +/- 5mm*
 - *360 degrees rotation clamp for best angle viewing*
 - *Non-Slip grip holds your device securely*
 - *Easy to use*
 - *High quality PC & ABS materials*
- *(tablet in image not included)*



**360 Degrees
Rotation**



**Secure
Grip**



**For Devices
7-13 inch**



GUARANTEE

Subject to the conditions stated below, groov-e guarantees this equipment against defects in workmanship or materials of its mechanical and electronic component parts (excluding styling, battery cells, magnetic tapes, re-chargeable batteries, user removeable memory devices, with the exception where the battery is inbuilt into the product) for a period of one year from the date of purchase. This product will be repaired or if necessary replaced free of charge if it has been proven to be defective within the one year warranty period.

1) Claims under this guarantee should be made through the authorised dealer/retailer from whom the equipment was purchased. If this is not possible, please contact groov-e directly.

2) This guarantee is only valid when the equipment is purchased and retained within the United Kingdom and a valid proof of purchase has been provided.

3) This Guarantee Excludes:

(i) All damage caused through accident, misuse, wear and tear, neglect, installation and/or use in a manner inconsistent with technical and safety standards.

(ii) Alterations or adjustments made to equipment

(iii) Loss of data resultant from malfunction of hard drive or other storage device

(iv) Damage caused to any third party device as a result of using the product.

4) No liability under this guarantee shall be incurred:

(i) In respect of damage or loss occurring during transit to or from the purchaser

(ii) Where the serial number plate of the equipment has been removed or altered in any way.

5) groov-e shall not be liable for consequential damage, loss or injury arising from or in connection with the equipment, excepting only that nothing in this condition shall or shall be construed so as to exclude or restrict liability for negligence.

- 6)** The cost of carriage to and from groov-e shall be borne by the purchaser.
7) This guarantee is personal to the original purchaser and is not transferable.
8) If the equipment, in respect of which a claim hereunder is made, is found on examination to comply with the published specifications, a test fee may be incurred.

This guarantee is in addition to and does not in any way affect any statutory or other right of consumer purchasers, including those rights in relation to sections 13 to 15 of the Sale of Goods Act 1979, the Sale and Supply of Goods to Consumer Regulations 2002, The Consumer Rights Act 2015 or the Sale of Goods and Supply of Services Act 1980 (for ROI).

groov»»e
Unit J
Braintree Road
Braintree Industrial Estate
Ruislip
Middlesex
HA4 0EJ

www.groov-e.co.uk
Email: info@groov-e.co.uk
Telephone: 020 8839 0978

Register your purchase for extended warranty
www.groov-e.co.uk/warranty

Authorised EU Representative
Rashmian EU Ltd
Robwyn House
Suite 3E
Corrintra
Castleblayney
Co. Monaghan
Ireland